

SWING-TYPE ( Semi-auto )

# Tyre Changer

**Middle-class configure, equipped with assistant inflating device.**

Time saving operation & reliable. suitable for middle-size tyre repair shop.



**AA-TC-185**

CE approved



**MOTOREX  
HOIST**

Since 2008

## MOTOREX features

- Hexangular shaft, used S41mm steel, not easy to distort, ensure the operation of low-profile and stiff tyre more safety.
- The turntable, use 515mm steel, the surface of the turntable is chrome plated, wearable and anti-septiced.
- Alloy material on mounting head to ensure hard-wearing
- This machine equipped with the protection cover for the mounting head, clamps, lever and bead breaker shoe, to avoid the damage for the aluminum alloy rim.
- The inflating system adopt gauge box, equipped with rubber inflating hose, ensure long working time and safety.
- This machine with "C" configure, "C" means tubeless tyre inflating device, make the edge of the tubeless tyre connect tightly with the rim, to avoid the leakage when inflating.
- Air tank is located in the vertical arm. Smart & space saving.



**TRUSTED  
VEHICLE LIFT  
SOLUTION  
PROVIDER**

[ SALES |  
INSTALLATION |  
PARTS & SERVICE ]

## Technical Parameters

<b>Motor power</b>	1.1kw
<b>Power supply</b>	240v 1PH
<b>Operation pressure</b>	8-10 bar
<b>Max. wheel dia</b>	44" (4420 mm)
<b>Max. wheel width</b>	14" (360 mm)
<b>Rim clamping from outside</b>	10"-21"
<b>Rim clamping from inside</b>	12"-24"
<b>Bead-breaker force</b>	2500 kg
<b>Noise</b>	<70 dB

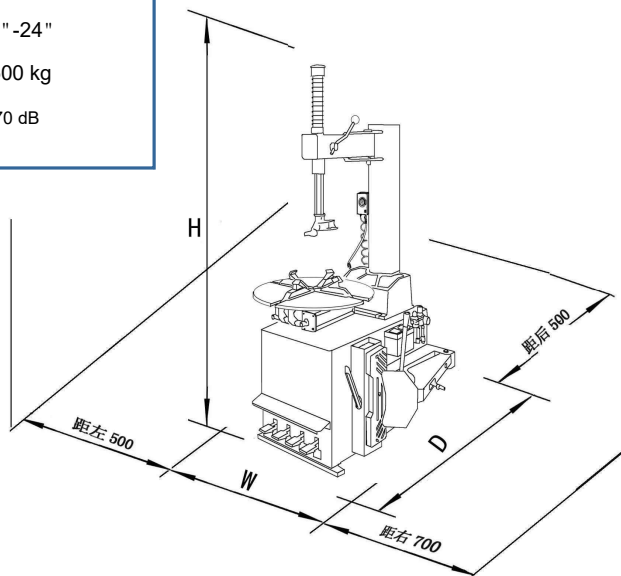

**MOTOREX \* PRICE \***

**\$2,500**

GST inclusive



**NATIONWIDE  
DELIVERY**

**NZ  
OWNED**  
Since 2008

[www.motorexhoist.com](http://www.motorexhoist.com)

**CALL: 021-2627162**

